



 **Primary 6 Science (Term 1) - Red Swastika (Y0)** 

**Add Questions** **Assign** **Settings** **Review**

 Duplicate  Print  Delete

 **Assign Test**

**Test Introduction**

[+ Add Introduction](#)

**31 Questions** (35 Points)

Question Bank: 12,655 Questions 

Test Questions **0 Test Assignments**

**Question 1**

Primary 6 Science » Primary 6 Science (Term 1)

2 pts

Study the flow chart below.

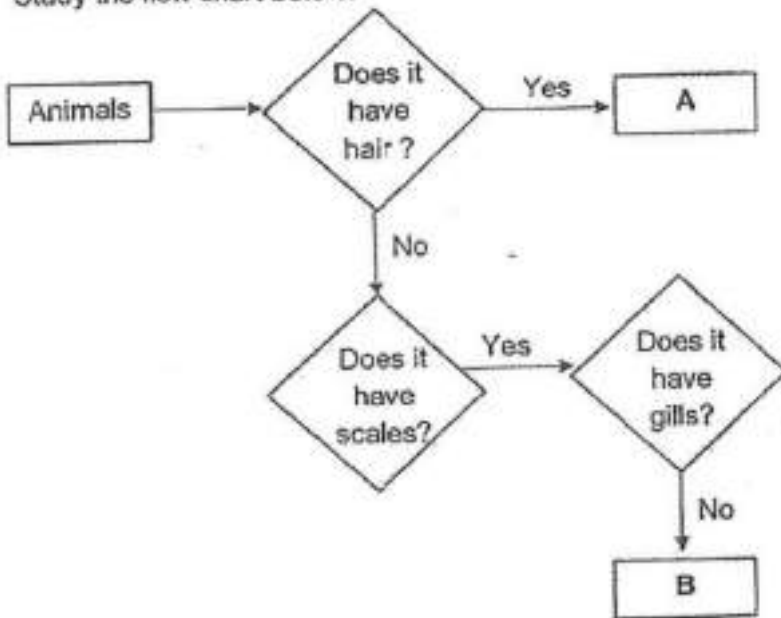

Which of the following is classified correctly for group A and B?

A.

A	B
insect	reptile

B.

A	B

mammal	fish
--------	------

C.

A	B
insect	fish

✓ D.

A	B
mammal	reptile

**Question Type:** Multiple Choice  
**Randomize Answers:** No  
**Date Added:** Fri 24th Sep 2021  
**Last Modified:** N/A  
**QID#:** 29,123,850

[↗ Answers](#) | [✎ Edit](#) | [📄 Duplicate](#) | [📌 Used In](#) | [⚙ Reorder](#)

[Remove From Test](#)

## Question 2

Primary 6 Science » Primary 6 Science (Term 1)

2 pts

Which statement is correct about the fern and the mushroom?

- A. They grow only on the ground.
- B. They are non-flowering plants.
- ✓ C. They reproduce from spores.
- D. They make their own food.

**Question Type:** Multiple Choice  
**Randomize Answers:** No  
**Date Added:** Fri 24th Sep 2021  
**Last Modified:** N/A  
**QID#:** 29,123,854

[↗ Answers](#) | [✎ Edit](#) | [📄 Duplicate](#) | [📌 Used In](#) | [⚙ Reorder](#)

[Remove From Test](#)

## Question 3

Primary 6 Science » Primary 6 Science (Term 1)

2 pts

Aminah wanted to find out how the length of the wing-like structure affects the distance travelled by the seeds.



Which of the following should be kept constant to ensure a fair test?

- A: location of the experiment
- B: length of the wing-like structure
- C: height from which the seeds were dropped

- A. A only

- B. A and C only
- ✓ C. B and C only
- D. A, B and C

**Question Type:** Multiple Choice  
**Randomize Answers:** No  
**Date Added:** Fri 24th Sep 2021  
**Last Modified:** N/A  
**QID#:** 29,123,858

[Answers](#) | 
 [Edit](#) | 
 [Duplicate](#) | 
 [Used In](#) | 
 [Reorder](#)

[Remove From Test](#)

## Question 4

Primary 6 Science » Primary 6 Science (Term 1)

2 pts

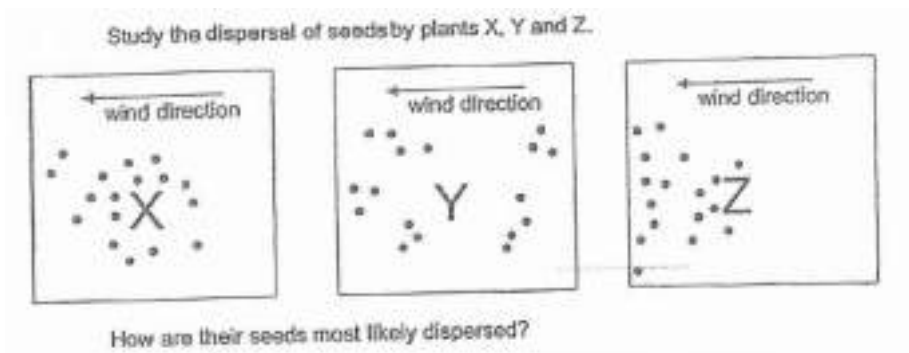

- A. 

X	Y	Z
animal	explosive action	wind
- ✓ B. 

X	Y	Z
explosive action	animal	wind
- C. 

X	Y	Z
animal	wind	explosive action
- D. 

X	Y	Z
wind	animal	explosive action

**Question Type:** Multiple Choice  
**Randomize Answers:** No  
**Date Added:** Fri 24th Sep 2021  
**Last Modified:** N/A  
**QID#:** 29,123,870

[Answers](#) | 
 [Edit](#) | 
 [Duplicate](#) | 
 [Used In](#) | 
 [Reorder](#)

[Remove From Test](#)

## Question 5

Primary 6 Science » Primary 6 Science (Term 1)

2 pts

Bryan observed two cells, X and Y, under the microscope. He completed the table below. A tick (✓) indicates that the part was observed in the cell.

Parts of cell	Cell X	Cell Y
nucleus	✓	✓
cell wall		✓
cytoplasm	✓	✓
chloroplasts		
cell membrane	✓	✓

Which of the following shows the correct classification?

- A. 

Cell X	Cell Y
cheek	leaf
- B. 

Cell X	Cell Y
root	cheek
- C. 

Cell X	Cell Y
onion	cheek
- ✓ D. 

Cell X	Cell Y
cheek	onion

Question Type: Multiple Choice  
 Randomize Answers: No  
 Date Added: Fri 24th Sep 2021  
 Last Modified: N/A  
 QID#: 29,123,880

[Answers](#) | [Edit](#) | [Duplicate](#) | [Used In](#) | [Reorder](#)

[Remove From Test](#)

### Question 6

Primary 6 Science » Primary 6 Science (Term 1)

2 pts

The diagram below shows the circulatory system in a fish and human.

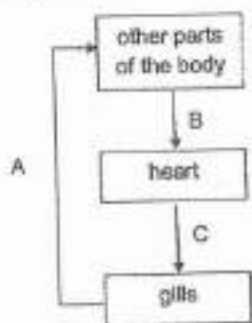

Circulatory system of a fish

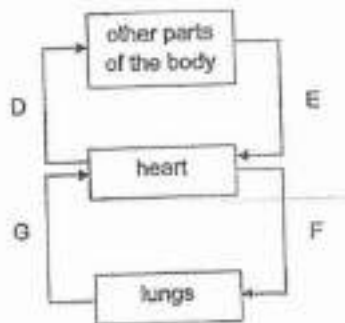

Circulatory system of a human

Which one of the following identifies oxygen-rich blood and carbon dioxide-rich blood at the different parts correctly?

- ✓ A. 

Oxygen-rich blood	Carbon dioxide-rich blood
A, D, G	B, C, E, F

B.	Oxygen-rich blood	Carbon dioxide-rich blood
	B, C, D, G	A, E, F

C.	Oxygen-rich blood	Carbon dioxide-rich blood
	C, G	A, B, E, D, F

D.	Oxygen-rich blood	Carbon dioxide-rich blood
	A, E, F	B, C, D, G

**Question Type:** Multiple Choice  
**Randomize Answers:** No  
**Date Added:** Fri 24th Sep 2021  
**Last Modified:** N/A  
**QID#:** 29,123,897

[Answers](#) | [Edit](#) | [Duplicate](#) | [Used In](#) | [Reorder](#)

[Remove From Test](#)

## Question 7

Primary 6 Science » Primary 6 Science (Term 1)

2 pts

Which of the following is produced by green plants during photosynthesis?

A: Food  
 B: Oxygen  
 C: Carbon dioxide

- A. A only  
 B. A and B only  
 C. A and C only  
 D. B and C only

**Question Type:** Multiple Choice  
**Randomize Answers:** No  
**Date Added:** Fri 24th Sep 2021  
**Last Modified:** N/A  
**QID#:** 29,123,906

[Answers](#) | [Edit](#) | [Duplicate](#) | [Used In](#) | [Reorder](#)

[Remove From Test](#)

## Question 8

Primary 6 Science » Primary 6 Science (Term 1)

2 pts

David set up the following experiment using green bean seeds.

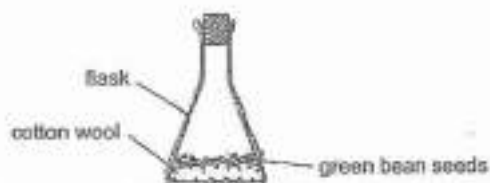

Which of the following conditions should he choose in order to have the seedlings with the thinnest stems at the end of his experiment?

- A. 

Location	Type of cotton wool	Number of green bean seeds
in the garden	moist	6
- B. 

Location	Type of cotton wool	Number of green bean seeds
in a dark cupboard	dry	30
- C. 

Location	Type of cotton wool	Number of green bean seeds
in the refrigerator	dry	6
- ✓ D. 

Location	Type of cotton wool	Number of green bean seeds
near the window	moist	30

**Question Type:** Multiple Choice  
**Randomize Answers:** No  
**Date Added:** Fri 24th Sep 2021  
**Last Modified:** N/A  
**QID#:** 29,123,921

[Answers](#) | [Edit](#) | [Duplicate](#) | [Used In](#) | [Reorder](#)

[Remove From Test](#)

## Question 9

Primary 6 Science » Primary 6 Science (Term 1)

2 pts

Rain boots are worn to protect the person from getting their feet wet when he/she walks in heavy rain.



Based on the properties shown below, which material is most suitable for making the rain boots?

<b>Key</b>
√ : yes
x : no

- A. 

Material	Property		
	Strong	Flexible	Waterproof
A	x	√	√
- ✓ B. 

B	√	√	√
---	---	---	---
- C. 

C	√	x	√
---	---	---	---
- D. 

D			
---	--	--	--

D	✓	✓	x
---	---	---	---

**Question Type:** Multiple Choice  
**Randomize Answers:** No  
**Date Added:** Fri 24th Sep 2021  
**Last Modified:** N/A  
**QID#:** 29,123,937

[Answers](#) | [Edit](#) | [Duplicate](#) | [Used In](#) | [Reorder](#)

[Remove From Test](#)

## Question 10

Primary 6 Science » Primary 6 Science (Term 1)

2 pts

Which of the following about condensation and evaporation in the water cycle is not correct?

- ✓ A. Evaporation occurs at a fixed temperature.
- B. Condensation happens when water vapour loses heat.
- C. Evaporation is affected by the temperature of the surroundings.
- D. Condensation causes the formation of clouds.

**Question Type:** Multiple Choice  
**Randomize Answers:** No  
**Date Added:** Fri 24th Sep 2021  
**Last Modified:** N/A  
**QID#:** 29,123,949

[Answers](#) | [Edit](#) | [Duplicate](#) | [Used In](#) | [Reorder](#)

[Remove From Test](#)

## Question 11

Primary 6 Science » Primary 6 Science (Term 1)

2 pts

Martin put three identical hot buns, of the same temperature, into three identical boxes, P, Q and R. The number of holes on the lid of the boxes are different.

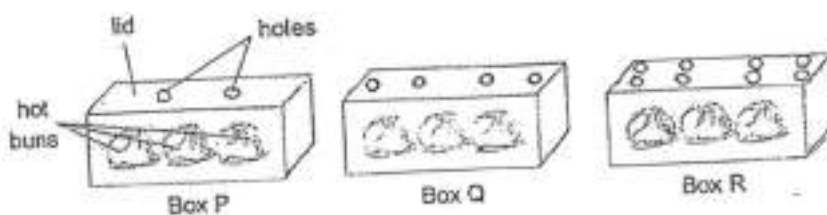

Based on information above, which of the following statements is correct?

- A. Water droplets formed on the inner surface of the box lids for P and Q only.
- B. The holes allow all the water droplets in the box to escape to the surrounding air outside the box.
- ✓ C. The most amount of water droplets dripped from the inner surface of the box lid onto the buns in box P.
- D. The most amount of water droplets dripped from the inner surface of the box lid onto the buns in box R.

**Question Type:** Multiple Choice  
**Randomize Answers:** No  
**Date Added:** Fri 24th Sep 2021  
**Last Modified:** N/A  
**QID#:** 29,123,974

[Answers](#) | [Edit](#) | [Duplicate](#) | [Used In](#) | [Reorder](#)

[Remove From Test](#)

## Question 12

Primary 6 Science » Primary 6 Science (Term 1)

2 pts

The diagram shows the arrangement of four bulbs in a circuit.

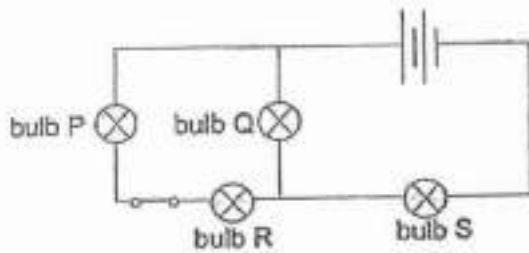

Which of the following bulbs can be turned on or off using the switch?

- A. Q and S only
- B. Q and R only
- ✓ C. P and R only
- D. P, Q and R only

**Question Type:** Multiple Choice  
**Randomize Answers:** No  
**Date Added:** Fri 24th Sep 2021  
**Last Modified:** N/A  
**QID#:** 29,124,021

[Answers](#) | [Edit](#) | [Duplicate](#) | [Used In](#) | [Reorder](#)

[Remove From Test](#)

## Question 13

Primary 6 Science » Primary 6 Science (Term 1)

2 pts

Ramesh kicked a ball upwards.

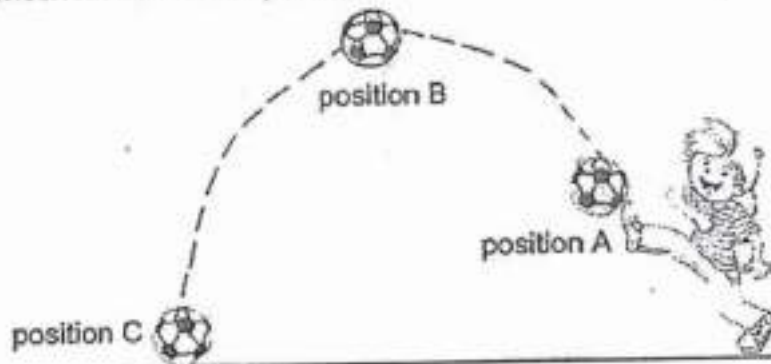

At which position(s) did gravitational force act on the ball?



- A. A only
- B. B only
- C. B and C only
- ✓ D. A, B and C

**Question Type:** Multiple Choice  
**Randomize Answers:** No  
**Date Added:** Fri 24th Sep 2021  
**Last Modified:** N/A  
**QID#:** 29,124,026

[Answers](#) | 
 [Edit](#) | 
 [Duplicate](#) | 
 [Used In](#) | 
 [Reorder](#)

[Remove From Test](#)

## Question 14

Primary 6 Science » Primary 6 Science (Term 1)

2 pts

Ahmad pushed his toy car across surface A.



He repeated the experiment by using the same amount of force on the toy car on three other different surfaces, B, C and D. The time taken for the toy car to come to a complete stop is recorded and shown below.

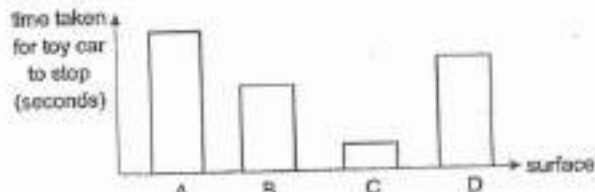

Based on information above, which of the following statements are correct?

- A: Surface C is the smoothest.
- B: Surface D is rougher than surface A but smoother than surface C.
- C: The frictional force between the toy car and surface A is the least.
- D: There is no frictional force acting between the toy car and surface C.

- A. A and B only
- ✓ B. B and C only
- C. B and D only
- D. A, B and C only

**Question Type:** Multiple Choice  
**Randomize Answers:** No  
**Date Added:** Fri 24th Sep 2021  
**Last Modified:** N/A  
**QID#:** 29,124,030

[Answers](#) | 
 [Edit](#) | 
 [Duplicate](#) | 
 [Used In](#) | 
 [Reorder](#)

[Remove From Test](#)

## Question 15

Primary 6 Science » Primary 6 Science (Term 1)

2 pts

A wire was coiled around a metal bar as shown below. At first, the metal ball did not move.

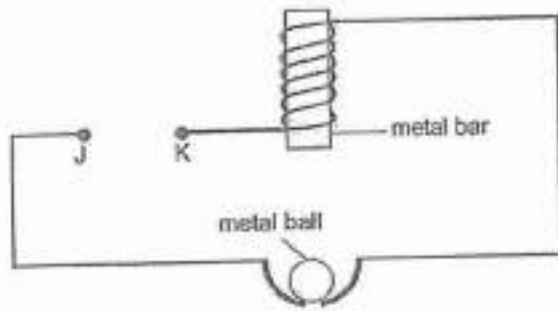

When a battery was placed in between points J and K, the metal ball moved towards the metal bar before dropping back down. This was repeated until the battery was removed.

What can be concluded based on the information above?

- A: The metal bar was a permanent magnet.
- B: The metal ball was made of a magnetic material.
- C: The metal ball dropped down as there was a closed circuit.

- ✓ A. B only
- B. A and C only
- C. A and B only
- D. B and C only

Question Type: Multiple Choice  
 Randomize Answers: No  
 Date Added: Fri 24th Sep 2021  
 Last Modified: N/A  
 QID#: 29,124,035

[Answers](#) | [Edit](#) | [Duplicate](#) | [Used In](#) | [Reorder](#)

[Remove From Test](#)

## Question 16

Primary 6 Science » Primary 6 Science (Term 1)

0.5 pts

The diagram below shows how a fruit is formed from flower X.

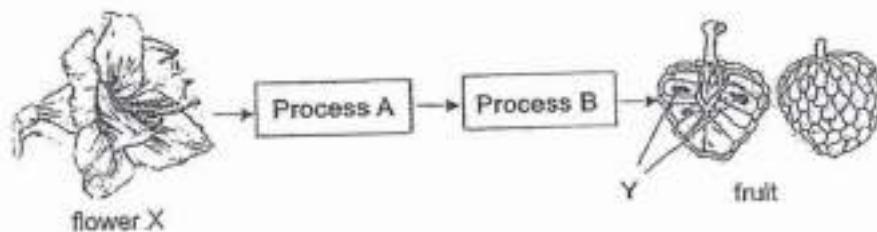

State process A.

Accepted answers:

- ✓ Pollination

Question Type: Free Text

Date Added: Fri 24th Sep 2021  
 Last Modified: N/A  
 QID#: 29,124,040

[Answers](#) | [Edit](#) | [Duplicate](#) | [Used In](#) | [Reorder](#)

[Remove From Test](#)

## Question 17

Primary 6 Science » Primary 6 Science (Term 1)

0.5 pts

The diagram below shows how a fruit is formed from flower X.

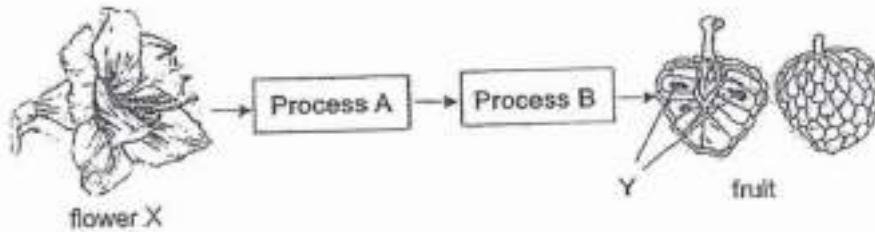

State process B.

**Accepted answers:**

✓ Fertilisation

**Question Type:** Free Text  
 Date Added: Fri 24th Sep 2021  
 Last Modified: N/A  
 QID#: 29,124,045

[Answers](#) | [Edit](#) | [Duplicate](#) | [Used In](#) | [Reorder](#)

[Remove From Test](#)

## Question 18

Primary 6 Science » Primary 6 Science (Term 1)

1 pt

The diagram below shows how a fruit is formed from flower X.

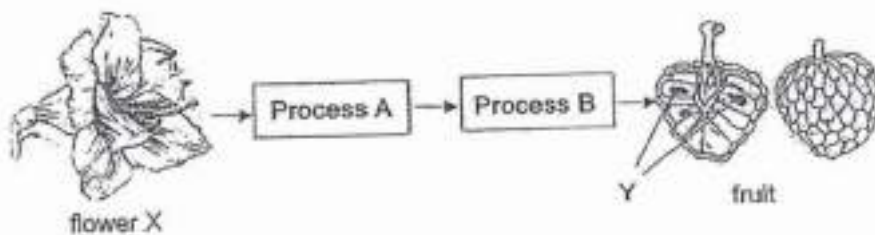

Which part of the flower did part Y of the fruit developed from?

**Accepted answers:**

✓ Ovules

**Question Type:** Free Text  
 Date Added: Fri 24th Sep 2021  
 Last Modified: N/A  
 QID#: 29,124,051

**Question 19**

Primary 6 Science » Primary 6 Science (Term 1)

0 pts

The picture shows organism Z, interacting with flower X.



Describe how organism Z helps in process A (2m)

This question is designed for extended answers that parent/ teacher will have to assign and guide child to attempt after the test has been completed.

Grading: This question type is not graded on this system and will not affect the final score as it was designed in such a way that it requires manual assistance.

**Question Type:** Essay  
**Date Added:** Fri 24th Sep 2021  
**Last Modified:** N/A  
**QID#:** 29,124,073

**Correctly answered feedback**

Organism Z helps to pollinate flower X when its body rubs on the anthers of flower X and the pollen grains stick onto its body. Thereafter, organism Z moves on to another flower and pollinates the flower when its body brushes on the stigma of the flower.

**Incorrectly answered feedback**

Organism Z helps to pollinate flower X when its body rubs on the anthers of flower X and the pollen grains stick onto its body. Thereafter, organism Z moves on to another flower and pollinates the flower when its body brushes on the stigma of the flower.

**Question 20**

Primary 6 Science » Primary 6 Science (Term 1)

0 pts

Peter conducted an experiment to investigate how the amount of light affected the mass of fruits in plant X over a period of time.

The graph below shows the result of the experiment.

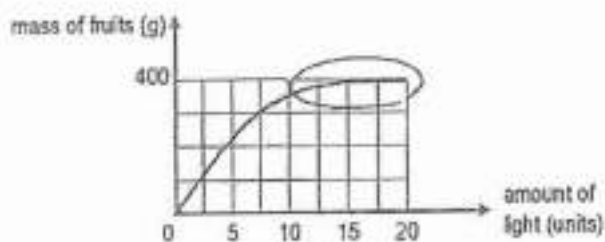

Based on the graph, state how the amount of light affected the mass of fruits produced by plant X. (2 marks)

This question is designed for extended answers that parent/ teacher will have to assign and guide child to attempt after the test has been completed.

Grading: This question type is not graded on this system and will not affect the final score as it was designed in such a way that it requires manual assistance.

**Question Type:** Essay  
**Date Added:** Fri 24th Sep 2021  
**Last Modified:** N/A  
**QID#:** 29,124,083

#### Correctly answered feedback

As the amount of light increased to 15 units, the mass of fruits increased. When the amount of light was 15 units and more, the mass of fruits remained the same.

#### Incorrectly answered feedback

As the amount of light increased to 15 units, the mass of fruits increased. When the amount of light was 15 units and more, the mass of fruits remained the same.

[Answers](#) | [Edit](#) | [Duplicate](#) | [Used In](#) | [Reorder](#)

[Remove From Test](#)

## Question 21

Primary 6 Science » Primary 6 Science (Term 1)

0 pts

Peter conducted an experiment to investigate how the amount of light affected the mass of fruits in plant X over a period of time.

The graph below shows the result of the experiment.

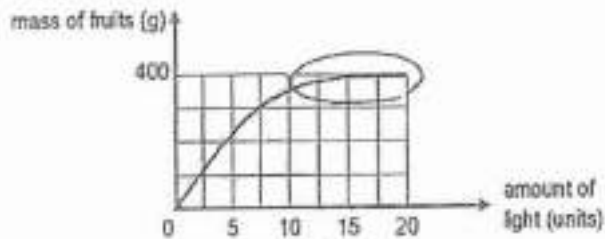

Peter decreased the amount of carbon dioxide used in the experiment. Explain what would happen to the mass of the fruits after some time. (2 marks)

This question is designed for extended answers that parent/ teacher will have to assign and guide child to attempt after the test has been completed.

Grading: This question type is not graded on this system and will not affect the final score as it was designed in such a way that it requires manual assistance.

**Question Type:** Essay  
**Date Added:** Fri 24th Sep 2021  
**Last Modified:** N/A  
**QID#:** 29,124,102

#### Correctly answered feedback

Mass of the fruits will decrease. With less carbon dioxide the rate of photosynthesis will decrease. The plant made less food. Less food would be transported to the fruit and stored in the fruit.

#### Incorrectly answered feedback

Mass of the fruits will decrease. With less carbon dioxide the rate of photosynthesis will decrease. The plant made less food. Less food would be transported to the fruit and stored in the fruit.

**Question 22**

Primary 6 Science » Primary 6 Science (Term 1)

0 pts

Jerome wanted to find out how the mass of a car affects the time taken for it to reach the bottom of a ramp. He set up the experiment below and gave the car a gentle push to let it move down the ramp.

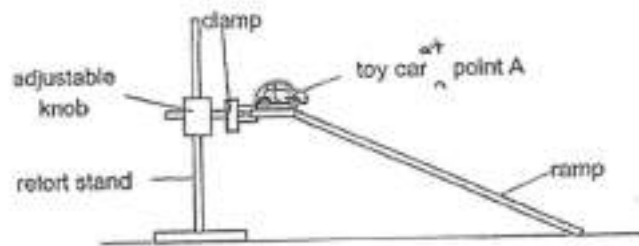

Fill in the boxes to show the energy conversion in the car as it moves down the ramp. (1m)

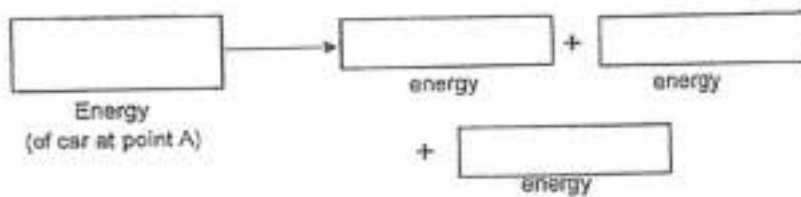

*This question is designed for extended answers that parent/ teacher will have to assign and guide child to attempt after the test has been completed.*

*Grading: This question type is not graded on this system and will not affect the final score as it was designed in such a way that it requires manual assistance.*

**Question Type:** Essay  
**Date Added:** Fri 24th Sep 2021  
**Last Modified:** N/A  
**QID#:** 29,124,114

**Correctly answered feedback**

Gravitational Potential -----&gt; Kinetic + Heat + Sound

**Incorrectly answered feedback**

Gravitational Potential -----&gt; Kinetic + Heat + Sound

**Question 23**

Primary 6 Science » Primary 6 Science (Term 1)

0 pts

Jerome wanted to find out how the mass of a car affects the time taken for it to reach the bottom of a ramp. He set up the experiment below and gave the car a gentle push to let it move down the ramp.

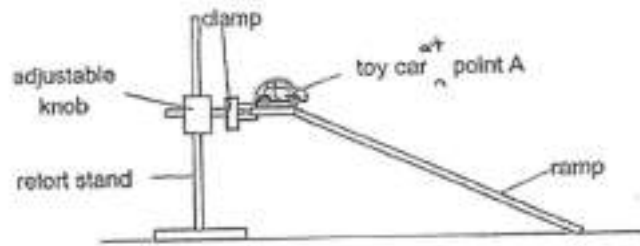

Without changing or adding any new apparatus or materials, state what he could do to make the car move down the ramp faster using the same force. (1 mark)

*This question is designed for extended answers that parent/ teacher will have to assign and guide child to attempt after the test has been completed.*

*Grading: This question type is not graded on this system and will not affect the final score as it was designed in such a way that it requires manual assistance.*

**Question Type:** Essay  
**Date Added:** Fri 24th Sep 2021  
**Last Modified:** N/A  
**QID#:** 29,124,126

#### Correctly answered feedback

Shift the adjustable knob to a higher position to raise the ram.

#### Incorrectly answered feedback

Shift the adjustable knob to a higher position to raise the ram.

[Answers](#) | [Edit](#) | [Duplicate](#) | [Used In](#) | [Reorder](#)

[Remove From Test](#)

## Question 24

Primary 6 Science » Primary 6 Science (Term 1)

0 pts

Jerome wanted to find out how the mass of a car affects the time taken for it to reach the bottom of a ramp. He set up the experiment below and gave the car a gentle push to let it move down the ramp.

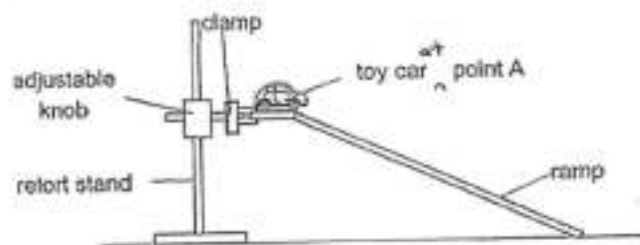

Explain your answer in the previous question. (1 mark)

*This question is designed for extended answers that parent/ teacher will have to assign and guide child to attempt after the test has been completed.*

*Grading: This question type is not graded on this system and will not affect the final score as it was designed in such a way that it requires manual assistance.*

**Question Type:** Essay  
**Date Added:** Fri 24th Sep 2021  
**Last Modified:** N/A

QID#: 29,124,133

**Correctly answered feedback**

When the slope is steeper, the car is higher, resulting in it having more gravitational potential energy, thus, more gravitational potential energy will be converted to more kinetic energy.

**Incorrectly answered feedback**

When the slope is steeper, the car is higher, resulting in it having more gravitational potential energy, thus, more gravitational potential energy will be converted to more kinetic energy.

[Answers](#) | [Edit](#) | [Duplicate](#) | [Used In](#) | [Reorder](#)

[Remove From Test](#)

**Question 25**

Primary 6 Science » Primary 6 Science (Term 1)

0 pts

Jerome wanted to find out how the mass of a car affects the time taken for it to reach the bottom of a ramp. He set up the experiment below and gave the car a gentle push to let it move down the ramp.

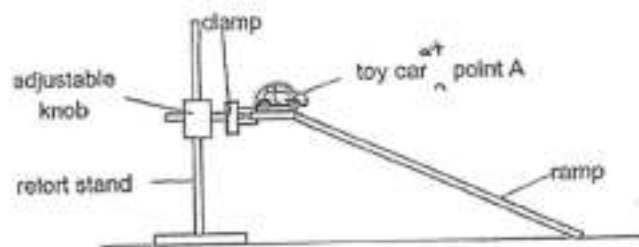

Jerome repeated the experiment by applying a layer of oil on the surface of the ramp. Explain what will happen to the time taken for the toy car to reach the bottom of the ramp. (1 mark)

*This question is designed for extended answers that parent/ teacher will have to assign and guide child to attempt after the test has been completed.*

*Grading: This question type is not graded on this system and will not affect the final score as it was designed in such a way that it requires manual assistance.*

**Question Type:** Essay  
**Date Added:** Fri 24th Sep 2021  
**Last Modified:** N/A  
**QID#:** 29,124,148

**Correctly answered feedback**

The time taken will be less. There is less friction between the car and the surface of the ramp.

**Incorrectly answered feedback**

The time taken will be less. There is less friction between the car and the surface of the ramp.

[Answers](#) | [Edit](#) | [Duplicate](#) | [Used In](#) | [Reorder](#)

[Remove From Test](#)

**Question 26**

Primary 6 Science » Primary 6 Science (Term 1)

1 pt



A weight is hung on spring A as shown below.

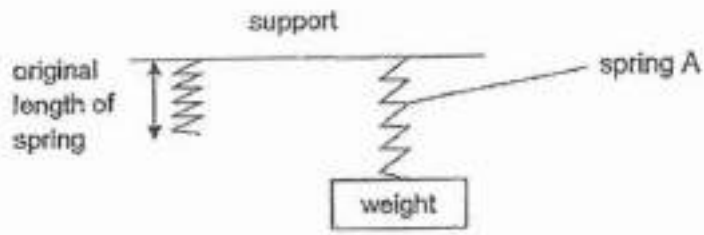

Name the force acting on the weight when it is hung on the spring. (1 mark)

**Accepted answers:**

✓ Gravitational force

**Question Type:** Free Text  
**Date Added:** Fri 24th Sep 2021  
**Last Modified:** N/A  
**QID#:** 29,124,161

[Answers](#) | [Edit](#) | [Duplicate](#) | [Used In](#) | [Reorder](#)

[Remove From Test](#)

## Question 27

Primary 6 Science » Primary 6 Science (Term 1)

1 pt

A weight is hung on spring A as shown below.

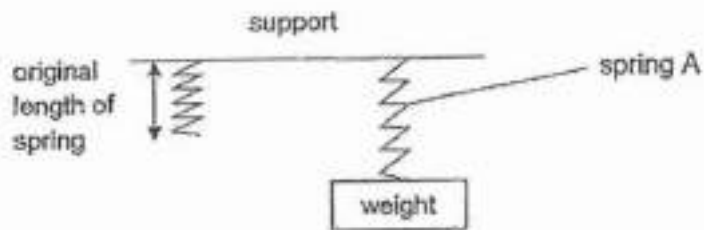

Five more identical weights were hung on spring A, one by one. The length of spring A was measured and recorded. The experiment was repeated using spring B.

The graph shows the results obtained.

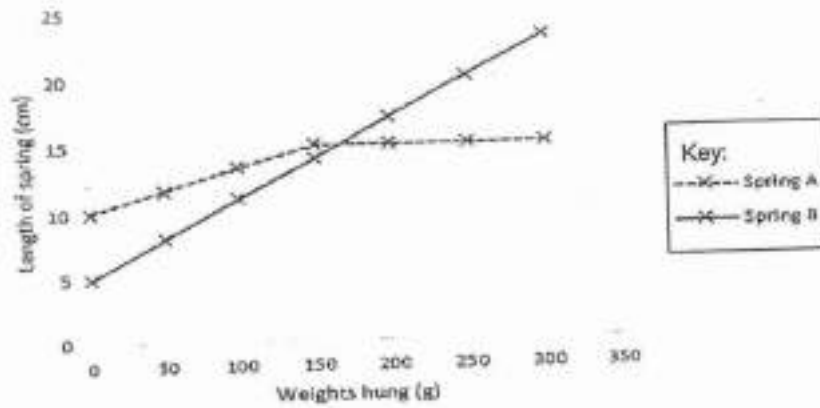

What is the original length of spring A? (1 mark)

Accepted answers:

- ✓ 10cm
- ✓ 10 cm
- ✓ 10

**Question Type:** Free Text  
**Date Added:** Fri 24th Sep 2021  
**Last Modified:** N/A  
**QID#:** 29,124,174

[Answers](#) | [Edit](#) | [Duplicate](#) | [Used In](#) | [Reorder](#)

[Remove From Test](#)

## Question 28

Primary 6 Science » Primary 6 Science (Term 1)

0 pts

A weight is hung on spring A as shown below.

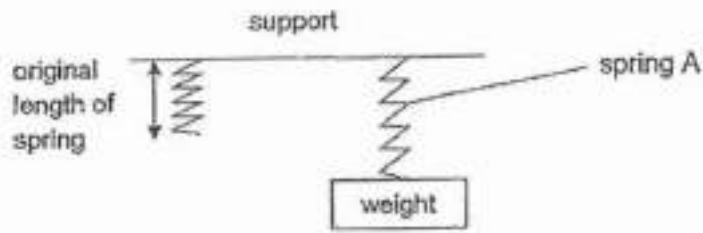

Five more identical weights were hung on spring A, one by one. The length of spring A was measured and recorded. The experiment was repeated using spring B.

The graph shows the results obtained.

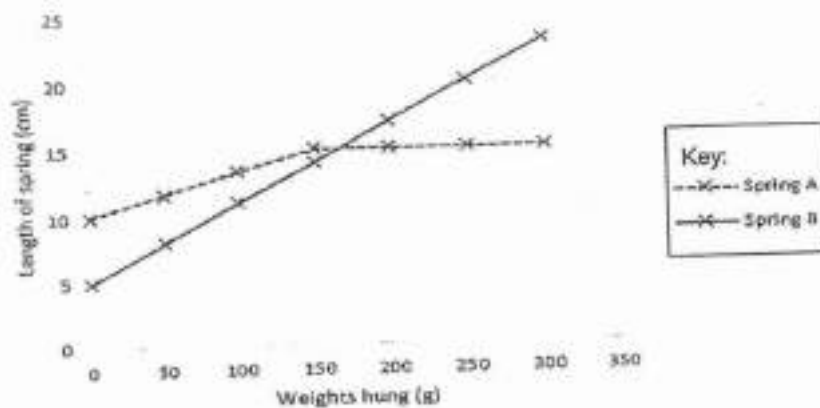

Which spring is more suitable for measuring objects weighing 250 g. Explain your answer. (2 marks)

*This question is designed for extended answers that parent/ teacher will have to assign and guide child to attempt after the test has been completed.*

*Grading: This question type is not graded on this system and will not affect the final score as it was designed in such a way that it requires manual assistance.*

**Question Type:** Essay  
**Date Added:** Fri 24th Sep 2021  
**Last Modified:** N/A  
**QID#:** 29,124,193

#### Correctly answered feedback

Spring B. Spring B can stretch to measure but Spring A cannot.

#### Incorrectly answered feedback

Spring B. Spring B can stretch to measure but Spring A cannot.

[Answers](#) | [Edit](#) | [Duplicate](#) | [Used In](#) | [Reorder](#)

[Remove From Test](#)

## Question 29

Primary 6 Science » Primary 6 Science (Term 1)

1 pt

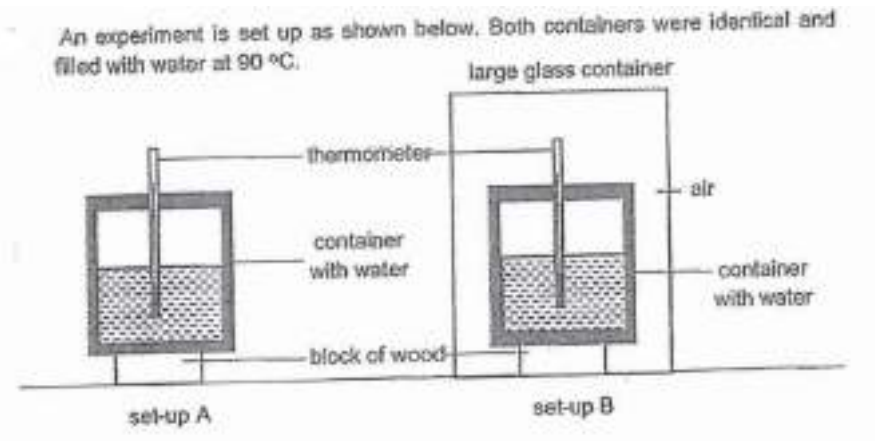

In which set-up, A or B, will the water be at a higher temperature after 30 minutes? (1 mark)

*This question is designed for extended answers that parent/ teacher will have to assign and guide child to attempt after the test has been completed.*

*Grading: This question type is not graded on this system and will not affect the final score as it was designed in such a way that it requires manual assistance.*

**Accepted answers:**

- ✓ Set-up B
- ✓ set up B
- ✓ setup b
- ✓ B

**Question Type:** Free Text  
**Date Added:** Fri 24th Sep 2021  
**Last Modified:** Fri 24th Sep 2021  
**QID#:** 29,124,206

[Answers](#) | [Edit](#) | [Duplicate](#) | [Used In](#) | [Reorder](#)

[Remove From Test](#)

## Question 30

Primary 6 Science » Primary 6 Science (Term 1)

0 pts

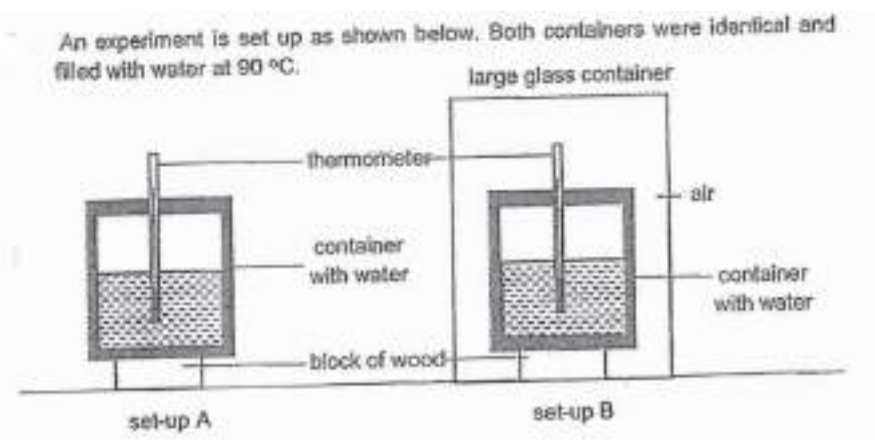

Explain your answer in the previous question. (2 marks)

*This question is designed for extended answers that parent/ teacher will have to assign and guide child to attempt after the test has been completed.*

*Grading: This question type is not graded on this system and will not affect the final score as it was designed in such a way that it requires manual assistance.*

**Question Type:** Essay  
**Date Added:** Fri 24th Sep 2021  
**Last Modified:** N/A  
**QID#:** 29,124,222

**Correctly answered feedback**

The layer of air is poor conducted of heat and reduces heat loss from the water to the surroundings.

**Incorrectly answered feedback**

The layer of air is poor conducted of heat and reduces heat loss from the water to the surroundings.

[Answers](#) | [Edit](#) | [Duplicate](#) | [Used In](#) | [Reorder](#)

[Remove From Test](#)

## Question 31

Primary 6 Science » Primary 6 Science (Term 1)

0 pts

An experiment is set up as shown below. Both containers were identical and filled with water at 90 °C.

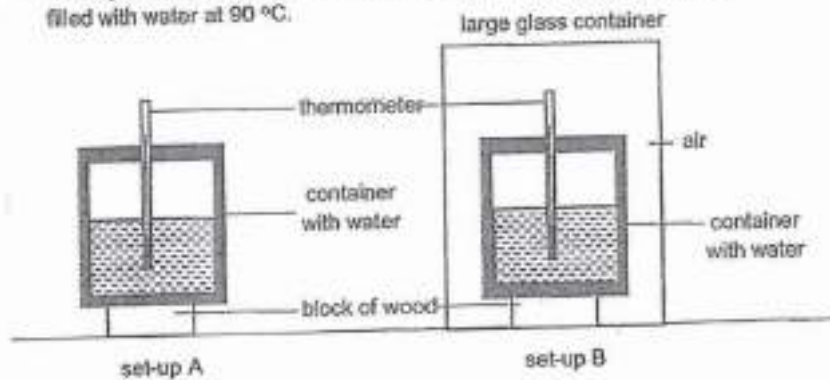

What will happen to the temperature of water in both set-ups after one day? (1 mark)

*This question is designed for extended answers that parent/ teacher will have to assign and guide child to attempt after the test has been completed.*

*Grading: This question type is not graded on this system and will not affect the final score as it was designed in such a way that it requires manual assistance.*

**Question Type:** Essay  
**Date Added:** Fri 24th Sep 2021  
**Last Modified:** N/A  
**QID#:** 29,124,228

**Correctly answered feedback**

They will both lose heat and reach room temperature.

**Incorrectly answered feedback**

They will both lose heat and reach room temperature.

[Answers](#) | [Edit](#) | [Duplicate](#) | [Used In](#) | [Reorder](#)

[Remove From Test](#)

